



EMERGENCY CLASSIFICATION

Mirador Surface

Non-maintained LED Emergency Light



The Mirador Surface is an ultra-bright wide angle surface emergency light that provides emergency illumination to allow the occupants of a building to safely exit in the event of mains power failure.

It is a non-maintained emergency light that achieves a high emergency classification of D80 as per AS/NZS 2293. It uses an environmentally friendly LiFePO4 battery with a long lifespan and a fast-charge rate.

It is well suited for use in commercial, retail, educational, industrial, strata & health care buildings.

Self-test is a touch-free function that comes standard with every Mirador product. Self-test automatically conducts regular duration tests every 3 months. The latest test results are always displayed via status indicators for easy viewing. This provides ease of compliance and peace of mind knowing that any functional issue on the product can quickly be identified.

OPTIONS AND BENEFITS

- **Operating Mode** - Non-Maintained
- **Emergency Classification:** D80
- **Slimline Surface Mount Box** with 1.2m flex & plug
- **Compliant to AS/NZS 2293**
- **IP20** - Ingress protection
- **Duration Self-Test:** Automatic duration testing every 3 months
- **Long life LiFePO4 battery**
- **5 year warranty** (including battery)

APPLICATIONS



CORRIDORS



HOSPITALS



OFFICES



RETAIL



SCHOOLS



STRATA



UNIVERSITY CAMPUSES

FEATURES



EASY INSTALL



EMERGENCY D80



INGRESS PROTECTION



LiFePO4 BATTERY



SAFETY COMPLIANCE



SELF TEST



SURFACE MOUNT



5 YEAR WARRANTY

PRODUCT RANGE

Model #	Rated Power (W)	Dimensions (mm)	Weight (kg)
MIRA-EL-D80-SM	4	205 x 160 x 55	1.05

DIMENSIONS

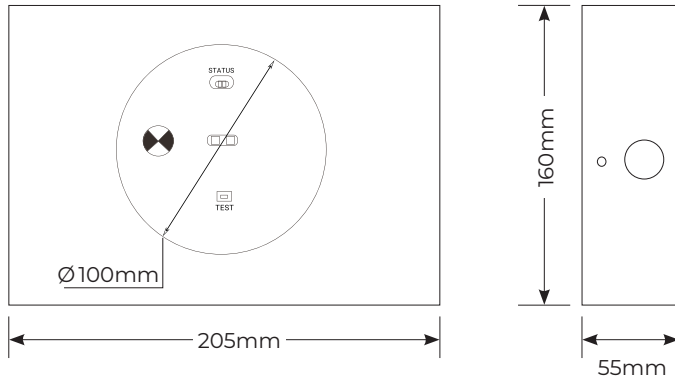

COMPLIANCE

The Mirador Surface Emergency light meets or exceeds all relevant standards and regulatory requirements.



For a full compliance and testing list visit www.enlighten.com.au. IES files, warranty, installation and product guides are also available for download.

Sold nationally through major electrical wholesalers.

TECHNICAL INFORMATION

Optical

Light source	Osram LEDs
Mode of operation	Non-Maintained
Emergency duration	> 180 minutes

Electrical

Power consumption (W)	1.26W
Operating voltage & frequency	220-240VAC, 50Hz
Battery type	LiFePO4
Battery rating	3.2V, 10.24Wh
Battery protection	Overcharge, low voltage disconnect, overcurrent, short circuit

Environmental

IP rating	IP20
Weight	1.05kg
Ambient temperature range	1°C to +40°C
Material Composition (body)	Powder coated metal box, flame retardant ABS disc

Controls

Indicators	Status LEDs
------------	-------------

Compliance

AS/NZS 2293 Classification	D80
----------------------------	-----

Warranty*	5 years (including battery)
-----------	-----------------------------

Data subject to change without notice
* Refer to warranty policy

AS/NZS 2293.1 SPACING TABLE

Emergency Classification: D80 (based on 0.2 lux criteria)

Mounting height	2.1	2.4	2.7	3	3.3	3.6	4	4.5	5	6	7	8	9	10	15	20
(a) Distance as per AS 2293.1:2018	11.5	13.2	14.8	16.5	18.1	19.8	22.0	24.7*	27.5*	28.9*	30.0*	30.9*	31.5*	32.1*	32.3*	28.8*
(b) Distance as per AS 2293.1:2005	21.1	22.0	22.8	23.6	24.3	25.0	25.8	26.7	27.5	28.9	30.0	30.9	31.6	32.1	32.4	28.9

(a) 2018 version of AS 2293.1 is applicable 2018 onwards for all projects for all new buildings, and on some pre 2018 buildings which specifically ask for compliance to the latest Emergency Lighting standards as part of a DA application, local council requirement, consultant specification etc.

(b) 2005 version of AS 2293.1 is still applicable on all retrofit projects, which do not specifically require to be compliant to the latest Emergency Lighting standards either via a DA application or through any other competent authority.

*Single emergency luminaire shall not serve an area of greater than 500m²

